

## 3 Way Tipping Gears

For 4x2 Rigid, 7.5 – 18 Tonnes GVW

**3W**

versatility

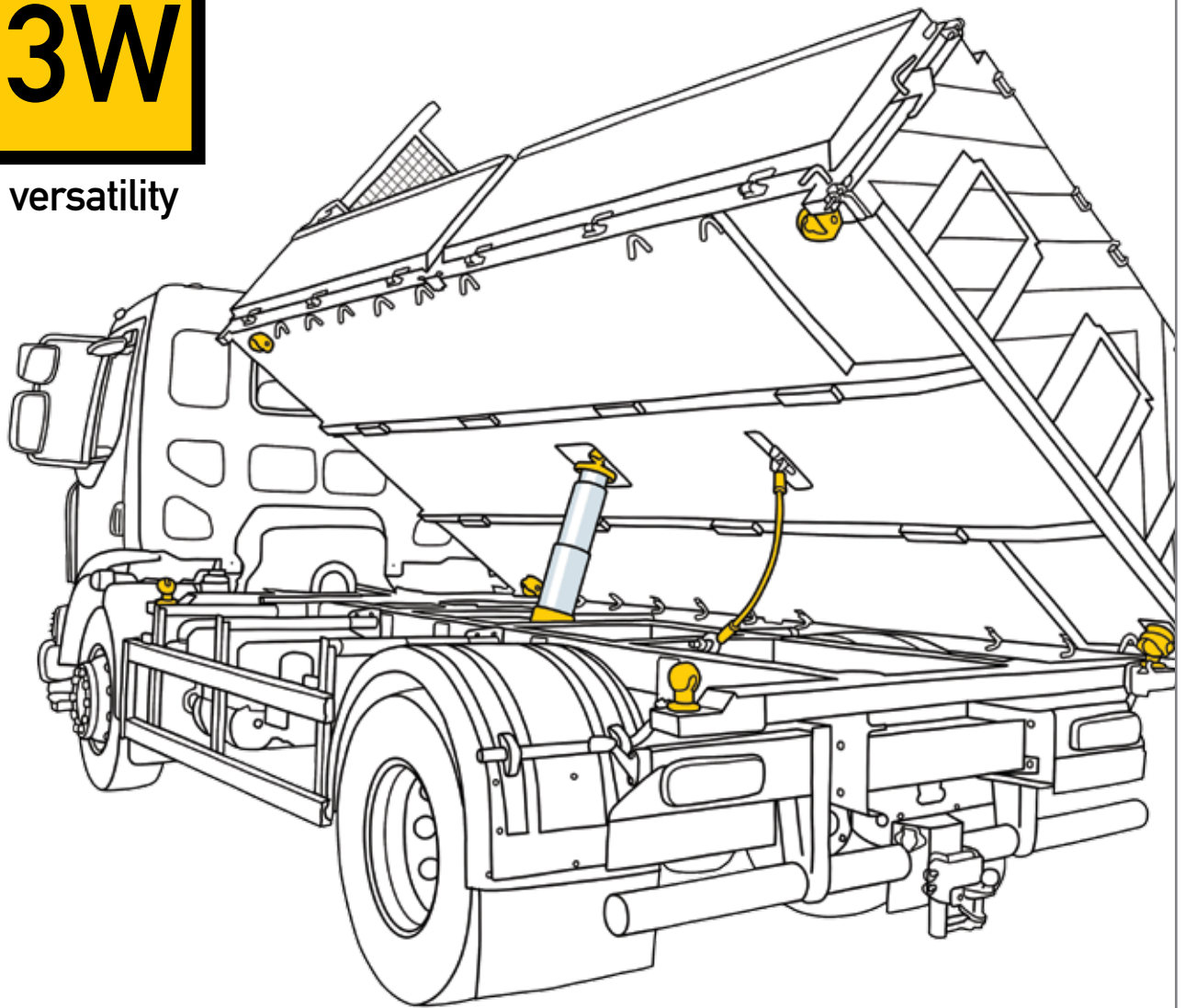

Harsh Limited  
The Industrial Estate, Full Sutton, York, YO41 1HS  
Tel: 01759 372100  
[www.harshuk.com](http://www.harshuk.com)

## 3 Way Tipping Gears

For 4x2 Rigid, 7.5 - 18 Tonnes GVW

### Why choose HARSH 3-Way?

Quite simply HARSH 3-Way gears give tippers the maximum possible operating versatility. Perfect for a full range of highways, local authority and utility uses, HARSH 3-Way gears enable the easiest possible placement of any type of load.

Ideally suited for bodies fitted with dropsides and tar chutes, HARSH 3-Way's highly responsive controls make any tipping operation precise and safe. Similarly, when side-tipping with 3-Way gears all personnel can remain on the pavement, out of danger from passing traffic.

HARSH 3-Way gears are also light in weight, allowing valuable extra payload in lighter 4x2 chassis. Small and compact, 3-Way gears are easy to mount in any vehicle chassis and, by being mounted out of harm's way under the body floor, are fully protected against accidental damage. Combining a simple design with chrome plated cylinders, HARSH 3-Way gears are almost completely maintenance-free.



versatility

### 3-Way Features & Benefits

- Maximum tipping versatility
- Low weight for greater payload
- Enhanced safety for vehicle crew
- Compact design, simple and easy to install
- Highest reliability with minimal maintenance
- Efficient and reliable
- Highly productive over a long service life

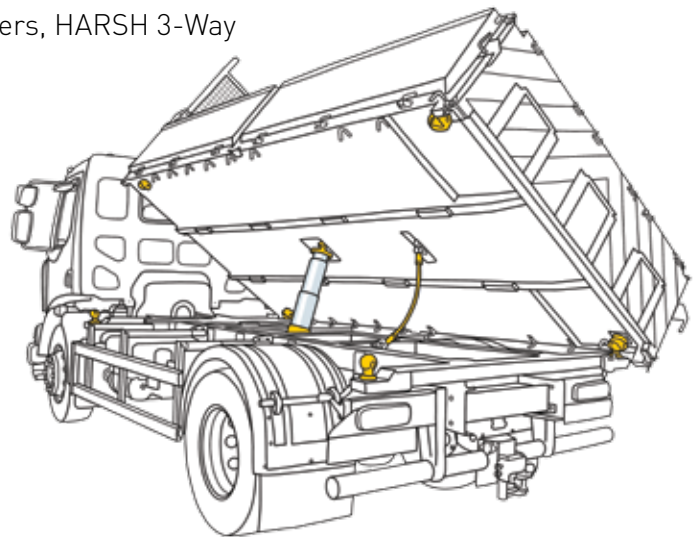

### 3-Way Models

- CU75 (7.5t), CU12 (12t), CU15 (15t), CU18 (18t), CU26 (26t), CU32 (32t)